

**CITY OF IRVING**  
**SOLICITATION OVERVIEW**

**The City of Irving is soliciting bids for:**

**TITLE:** Standard Dark Bronze Signal Pole Assemblies  
**ITB #:** 046D-10F  
**Commodity:** 9845 and 9846, Traffic Signals and Accessories  
**Due Date:** 3:00 p.m., Friday, November 13, 2009  
**Location:** City of Irving, Purchasing Division  
845 W. Irving Blvd.  
Irving, Texas 75060

**Pre-Bid Conference:**

There will be no pre-bid conference for this ITB

**Public Bid Opening:**

There will be a public bid opening in the Purchasing Division Conference Room immediately following the bid due time/date. Interested parties are invited to attend.

**Written Questions:**

Submit written questions to:

Darlene Rush, Senior Purchasing Agent, [drush@cityofirving.org](mailto:drush@cityofirving.org) and  
Belinda Younger-Gurley, Traffic Signal Superintendent, [bgurley@cityofirving.org](mailto:bgurley@cityofirving.org).

Questions may be submitted through 3:00 p.m., November 5, 2009.

Questions of a substantial nature will be addressed in an addendum, posted on the City's Purchasing Web page for all interested parties.

# **CITY OF IRVING**

## **TABLE OF CONTENTS for ITB 046D-10F**

Solicitation Overview .....	1
Table of Contents .....	2
Specifications .....	3-6
Bid Pricing Page.....	7
Summary Response Page .....	8
Attachment A-1, Standard Terms and Conditions .....	9-13
Attachment B-1, General Instructions to Bidders .....	14-15
Attachment B-2, Special Instructions to Bidders .....	16
Attachment B-3, Checklist for Bidders.....	17
Attachment B-5, Map Locating Purchasing Division.....	18
Attachment C-1, Conflict of Interest Instructions .....	19
Attachment C-2, Conflict of Interest Statement .....	20-21
Attachment D-9, No Insurance Requirements.....	22
Attachment E-1, Environmental Commitment .....	23
Attachment E-2, Environmental Stewardship .....	24
Attachment F-1, Good Faith Effort Program Overview .....	25
Attachment F-2, Good Faith Effort Affidavit .....	26
Attachment G-9, No Bonding Requirements .....	27
Attachment H-1, Instructions for Standard Contract .....	28
Attachment H-2, Standard Contract and Acknowledgement .....	29-30
Attachment I-1, Drawing.....	31

## Specifications

**INTENT:** The intent of these specifications is to award an annual contract to purchase traffic assemblies to be used by the City of Irving's Transportation Department/Traffic Division. This specification describes the minimum acceptable requirements.

**Contract Period** - This contract begins with date of award **and runs through December 31, 2010.**

**Renewal Option** - This contract is subject to consideration for two renewals with each renewal being for a one-year period of time and under the same terms and conditions as awarded or with negotiated lower pricing. Each renewal option may be exercised by the City of Irving with written agreement by contractor.

### STANDARD DARK BRONZE TRAFFIC SIGNAL ASSEMBLIES

**GENERAL:** These specifications and the City of Irving, Texas Drawing, Attachment I are intended to describe for the purchase of round steel traffic signal mast arm pole assemblies. The round all-steel assemblies will be utilized for mounting traffic signal heads and traffic signs adjacent to and over roadways.

The entire assemblies are to be designed in accordance with the current American Association of State Highway and Transportation Officials (AASHTO) *Standard Specifications for Structural Supports for Highway Signs, Luminaires and Traffic Signals*, Texas Department of Transportation, *American Welding Society (AWS)*, *American Institute of Steel Construction (AISC)*, and other specifications of this body as may be pertinent. Each assembly shall be designed to support: the dead loads shown on the drawings; weights of the traffic signals, mast arms, signs, etc.; and, wind and ice loads on the specified signal heads, signs, and on all surfaces of the assembly. Wind speeds used for design shall be based on a 50-year mean recurrence interval, gust factor of 1.4 and a drag coefficient of 1.2. The round traffic signal mast arms are to be in a horizontal plane when loaded as shown on the drawings. All traffic signal mast arms shall be continuous in length. The traffic signal mast arms are to be rigidly fastened with flush and uniform contact to the pole plate as shown on the drawings without having to make any modifications whatsoever when installed (no clamp-on fittings will be acceptable). All traffic signal heads and signs will be rigidly mounted.

All assemblies must conform to the Specifications and drawings as to height, general design and finish. The tapered poles and arms must be round, and assemblies with other than round tapered poles and arms are not acceptable. The entire assembly shall be galvanized as specified herein.

**If the manufacturer's proposed product fails to meet any of the requirements set forth in either of these specifications or the drawings, such exceptions must be noted on the bid proposal form and shall be depicted on accompanying drawings.**

**ROUND SIGNAL POLES:** The round signal poles are to be designed to support the loading shown on the drawings and as herein described for type C pole design:

**Type C Signal Pole** (see Attachment I). The round pole shall be designed for the 44-ft. signal mast arm assembly. All Type C signal poles shall be identical in all respects.

A base plate with a round opening of a size to receive the round pole shall be welded to the end of the pole by continuous welds (see drawings). The base plate and welds shall be such to develop the strength of the adjacent pole section. Four (4) holes shall be provided in the plate to receive anchor bolts (the holes shall be ¼" larger than the anchor bolts).

Four (4) anchor bolts are to be furnished for each signal pole. The length, diameter, and the treatment of the embedded end of the bolts shall be such as to meet all applicable requirements. Each anchor bolt shall be threaded at the top and fitted with two (2) nuts and two (2) flat washers.

A pole plate shall be welded to the round pole at the location shown on the drawings. The plate shall be designed so that a signal mast arm can be rigidly attached to the pole with the furnished four (4) high-strength bolts. The pole plate surface must be free of surface imperfections or anything that would prevent flush and uniform contact with the signal mast arm.

Reinforced handholes with covers shall be furnished as shown on the drawings. Screws that are either stainless or galvanized shall attach covers. The manufacturer may offer his standard design providing the nominal dimensions are maintained.

The round pole shall have a "J" hook welded near the top for wiring support, shall be furnished with a removable pole top cap, and shall be furnished with a full base cover.

**ROUND SIGNAL MAST ARMS:** The round signal mast arms are to be designed to support the loading shown on the drawings and as previously herein described.

**The length of the arm shall be one continuous piece with an end-of-arm welded arm plate and furnished with a removable end-of-arm cap.**

An arm plate shall be welded to the round mast arm as shown on the drawings. The plate shall be designed so that the arm can be rigidly attached to the signal pole with four (4) high-strength bolts (the bolts are to be furnished). The Type C arm plate must match the pole plate that it is to be attached to. The four (4) holes provided in the arm plate shall be 1/8" larger than the diameter of the high-strength bolts.

The internal weld of the socket connection, between the arm plate to pole plate, must not protrude past the arm plate. The weld must not interfere with providing uniform contact between the surfaces of the arm plate and the pole plate. Grinding the weld down to be even with the arm plate will not be accepted.

The arm plate surface must be free of any surface imperfections, weld protrusions, or anything that would prevent flush, intimate, and uniform contact with the pole plate.

**FABRICATION AND WELDING:** All poles and arms shall be fabricated from hot-rolled commercial quality carbon steel with a guaranteed minimum yield strength of 55,000 psi after fabrication and shall have only one longitudinal welded joint and shall have no horizontal welded joint beyond the base of the member. All materials shall be new and unused and made by a United States of America manufacturer.

After forming and welding, the round poles and arms may be longitudinally rolled under sufficient pressure to flatten the weld. The welds shall be smooth so as to obtain the appearance characteristics of the member itself. All welded joints shall develop the full-required strength of the welded member. All welds shall meet the requirements of AASHTO, AWS, and AISC.

All surfaces shall have a workmanlike finish. No sharp unfilleted angles or corners will be allowed. The signal pole shall be free of holes except for the wiring access holes and the hand-holes. No plugs or patches will be accepted.

**GALVANIZING:** The complete assembly, including all parts used in the assembly with the exception of the standard length galvanizing on the anchor bolts, shall be completely hot-dipped galvanized after fabrication in accordance with the ASTM Designation A123. All screws, nuts, bolts, washers and at least the upper nine (9) inches of the anchor bolts shall be galvanized in conformance with the specifications of ASTM Designation A153, Class C or D. All threaded material shall be brushed or re-tapped after galvanizing.

The galvanized faying surfaces of the connectors between the signal mast-arms shall be free of surface imperfections, such as lumps, runs, and scum, or anything which would prevent intimate uniform contact between faying surfaces.

Any part of the assembly from which the galvanizing has been knocked or chipped off down to bare metal in fabrication or transit shall be repaired in a professional manner by the supplier so as to provide an assembly which is neat in appearance.

**STANDARD POLE POWDER FINISH COAT:** The exterior steel surfaces shall be blast cleaned to Steel Structures Painting Council Surface Preparation Specification No. 6 (SSPC-SP6) requirements utilizing cast steel abrasives conforming to the Society of Automotive Engineers (SAE) Recommended Practice J827.

All exterior surfaces shall be coated with either Urethane or Triglycidyl Isocyanurate (TGIC) Polyester Powder to a minimum dry film thickness of 2.0 mils (.002") for urethane powder or 3.0 mils (0.003") for TGIC powder. The coating shall be electrostatically applied and cured in a gas fired convection oven by heating the steel substrate to a minimum of 350 degrees Fahrenheit and a maximum of 400 degrees Fahrenheit. The powder coat finish shall be dark bronze color.

Interior surfaces of the signal-pole shafts at the base end for a length of approximately 2.0' should be mechanically cleaned and coated with a zinc rich epoxy powder. The coating should be electrostatically applied and cured in a gas fired convection oven by heating the steel substrate to a minimum of 350 degrees Fahrenheit and a maximum of 400 degrees Fahrenheit.

Extra care shall be taken to protect the finish during transportation. Any part of the assembly, from which the powder coat has been knocked, scratched or chipped off in fabrication or in transit shall be repaired in a professional manner by the supplier to the approval of the City.

Because scratches can occur on poles during installation, the Respondent shall provide the City with an extra two (2) gallons of paint to be used for touch up. Touch up paint shall be same color as poles.

**DECORATIVE LOW BASE COVER:** Valmont Classic Clamshell CL31-AB series or equivalent decorative Low Base cover for type C standard signal poles

The decorative aluminum base is constructed of two identical cast clamshells A319 alloy aluminum or equivalent. Parts are cast whole or in components welded together prior to application of finish.

Connection hardware shall be stainless steel socket head style bolts. All hardware is accessible from outside the base for easy installation. Halves are factory fitted and shipped together. Each half is identical with an integral door designed to fit the aesthetic appearance of the base. Doors are supplied with stainless steel socket style screws.

The clamshell base is designed to wrap around the pole with a circular hole with a tolerance of .25" maximum clearance between the base and the casting. The outside opening is designed to accommodate the outside diameter of the type C standard signal pole.

The finish for the base is polyester Dark Bronze powder coating.

Size is 31" diameter x 13.6" height - to allow access to standard signal pole hand-hole.

**SPECIFIC REQUIREMENTS FOR THE SUCCESSFUL BIDDER:** The successful bidder shall submit the following after award:

1. Three (3) copies of detailed designed drawings of each pole assembly.
2. Three (3) copies of the design strength calculations for each pole assembly. Calculations shall be by a registered professional structural or civil engineer whose license is current and active.
3. All material of each component shall be referenced to ASTM Specifications, or to other specifications, with minimum yield points or yield strength shown.
4. A certificate signed by an official of his firm, which states that:
  - A. The materials and pole assembly he proposes to provide will meet the specifications included herein unless an exception is noted on the Bid Document.
  - B. The pole assembly he proposes to provide meets the accepted design standards and requirements of the current AASHTO, AWS, and AISC publications. Where there is contradiction, AASHTO shall govern.
5. The successful bidder will be required to ship all anchor bolts and anchor bolt templates with receipt of order.
6. The successful bidder shall bear all expenses connected with the repair or replacement of any defective material(s) during the guarantee period.
7. All warranties and/or guarantees with respect to materials, workmanship and performance of his product; if not previously supplied with his bid.
8. Items #1 and #2 shall be submitted to the City of Irving for approval prior to fabrications.
9. Delivery of the assemblies must be within 180 calendar days after receipt of order.

**If any of the above requirements are not met or provided for as specified, the order will be considered incomplete and payment will be withheld until above items are received and accepted by the City's Transportation Department/Traffic Division.**

**Pricing Page**

Item	Est. Yearly Qty.	Description	Unit Price	Total Price
<b>STANDARD TRAFFIC SIGNAL ASSEMBLIES</b>				
1	20 ea.	Type C Signal pole with 44' arm, Galvanized with external etching process for Dark Bronze Powder Coating, per attached specifications.  Make / Model _____ _____  Delivery can be made within _____ calendar days.	_____	_____
<b>TOTAL</b>				\$ _____

# CITY OF IRVING

## SUMMARY RESPONSE PAGE for ITB 046D-10F

**COMPLETE LEGAL NAME** of firm submitting bid:

\_\_\_\_\_

**Mailing Address:** \_\_\_\_\_

**City, State, & Zip:** \_\_\_\_\_

**Phone:** \_\_\_\_\_ **E-mail Contact:** \_\_\_\_\_

**GRAND TOTAL of bid from Bid Pricing Page** \$ \_\_\_\_\_

**Authorized Signature** \_\_\_\_\_ **Date** \_\_\_\_\_

Signature indicates bidder accepts the specifications, terms and conditions of this solicitation and that bidder is not delinquent on any payment due the City nor involved in any lawsuit against the City.

**Print Name** \_\_\_\_\_ **Title** \_\_\_\_\_

**ARE YOU BIDDING as a** \_\_\_\_\_ **Corporation** \_\_\_\_\_ **Non-Profit Corporation**  
\_\_\_\_\_ **Limited Liability Company** \_\_\_\_\_ **Partnership**  
\_\_\_\_\_ **Individual or Sole Proprietor**

**M/WBE:** If you are a minority-owned or woman-owned business, please check which type and list any certification number \_\_\_\_\_ **Black** \_\_\_\_\_ **Hispanic** \_\_\_\_\_ **Asia-India** \_\_\_\_\_ **Asia-Pacific**  
\_\_\_\_\_ **Native American** \_\_\_\_\_ **Woman-Owned** \_\_\_\_\_ **Certification #** \_\_\_\_\_

**PAYMENT TERMS:** Normal payment terms are 2%/30 days. If offering other terms/discount, please specify \_\_\_\_\_. Discount will be considered in award.

**PAYMENT PREFERENCE:** Check all that apply:  
\_\_\_\_\_ **EBT (electronic bank transfer)** \_\_\_\_\_ **Check** \_\_\_\_\_ **Credit card**

**COOPERATIVE PURCHASES:** Should other governmental entities decide to participate in this contract, would you agree that all terms, conditions, specifications and pricing would apply? Yes \_\_\_\_\_ No \_\_\_\_\_. If other governmental entities choose to participate, each entity will place its own order and be responsible for its own payments.

**REFERENCES:** This solicitation requires references. Please attach to this page a list of three references either currently doing business with you or having purchased goods or services within the past 24 months. For each reference list name, contact person, address, telephone, and e-mail address, and any other pertinent information to help the City of Irving verify the quality of goods or services your firm provides.

# STANDARD TERMS AND CONDITIONS

## Attachment A-1 (rev. 12/31/08)

### 1. Application

These standard terms and conditions shall apply to all City of Irving (hereafter "City") solicitations and procurements, unless specifically excepted in the solicitation specifications.

### 2. Requirements

By submitting a bid or proposal, the respondent agrees to provide the City of Irving with the specified goods or services described in the solicitation in accordance with these standard terms and conditions, at the agreed upon bid price and in compliance with the stated specifications and any subsequent addendums issued prior to the date of the bid opening.

### 3. Legal Compliance

Bidder or proposer must comply with all Federal, State and Local laws, statutes, ordinances, regulations and standards in effect at the time of delivery of goods and services, and must maintain any and all required licenses and certificates required under the same laws, statutes, ordinances, regulations and standards for services and/or goods provided in response to this solicitation.

### 4. Estimated Quantities

If the solicitation calls for unit pricing on specific items, the quantities described for each item are estimates only and not guaranteed amounts. The actual amount ordered over the contract period may be more or less than the estimate. Quantities represent the City's best estimate, based on past history and anticipated purchases.

### 5. Modifications and Addendums

The City shall have the right to modify any of the solicitation documents prior to submission deadline and will endeavor to notify potential bidders, but failure to notify shall impose no liability or obligation on the City. All modifications and addendums must be in written form prepared by the City department issuing the solicitation. Bidders are responsible for incorporating any and all modifications and addendums into their bid responses.

### 6. Interpretation of Solicitation Documents

The City is the final judge of the meaning of any word(s) sentences, paragraphs or other parts of the solicitation documents. Bidders are encouraged to seek clarification, before submitting a bid, of any portion of the bid documents that appears to be ambiguous, unclear, inconsistent, or otherwise in error. Clarifications will be in writing.

### 7. Late Bids

Bids must be received in the Purchasing Office by the time specified in the solicitation. The City will not accept late bids and is not responsible for the lateness or non-delivery of bids by the Postal Service or any private delivery firm. The time/date stamp in the Purchasing Office shall be the official time of receipt.

### 8. Conditional Bids

The City will not accept conditional bids which qualify the bidder's response in any way.

### 9. Minor Irregularities

The City reserves the right to waive any minor irregularities that do not materially affect the scope or pricing of submitted bids.

10. Responsiveness of Bids

The City wants to receive competitive bids, but will declare “non-responsive” bids that fail to meet significant requirements outlined in the solicitation documents.

11. Discrepancies and Errors

In the case of a discrepancy between the unit price and the extended total for a bid item, the unit price will prevail. The unit prices of bids that have been opened may not be changed for the purpose of correcting an error in the bid price.

12. Identical Bids

In the event two or more identical bids are received, and are lowest, responsible and responsive, award will be made as prescribed in the Texas Local Government Code, Chapter 271.901.

13. Reciprocal Local Preference

Some states provide a preference for vendors within their borders and add percentages to bids received from outside states. Where this happens, the state of Texas responds in like manner by applying the same percentage to bids received from vendors who are not from Texas. This applies to the purchase of materials, supplies, equipment and services.

14. Withdrawal of Bids

Bidders may withdraw any submitted bids prior to the bid submission deadline. Bidders may not withdraw once the bids have been publicly opened, without the approval of the City’s purchasing manager. Bidders will be allowed to withdraw bids that contain substantial mathematical errors in extension

15. Disqualification of Bidder

The City may disqualify bidders, and their bids not be considered, for any of the following reasons: Collusion among bidders; Bidder’s default on an existing or previous contract with the City, including failure to deliver goods and/or services of the quality and price bid; Bidder’s lack of financial stability; any factor concerning the bidder’s inability to provide the quantity, quality, and timeliness of services or goods specified in the solicitation; bidder involved in a current or pending lawsuit with City; bidder’s attempt to influence the outcome of the solicitation through unauthorized contact with City officials outside of those listed in the solicitation documents; and bidder’s attempt to offer gifts, gratuities, or bribes to any City employee or elected official in connection with a solicitation.

16. Cost of Bid

The cost of submitting bids shall be borne by the bidders, and the City will not be liable for any costs incurred by a bidder responding to this solicitation.

17. Inclusive Pricing

Bid pricing is to include all expenses, fees and charges related to the delivery of the specified goods or services. The City will not pay any additional charges other than the bid price unless requested by the City on the bid response sheet.

**18. Firm Prices**

Unless otherwise stated in the specifications, bidder's prices remain firm for 120 days from date of bid opening and, upon award, remain in effect for the contract period specified in the solicitation. If formal award has not occurred within 120 days of bid opening, the vendor and the City may mutually agree to extend the firm price period.

**19. Delivery Terms**

Unless otherwise stated in the specifications, all goods delivered through this solicitation shall be FOB City of Irving specified delivery address or site.

**20. Transportation Charges**

Bidder shall be responsible for all charges which relate to the delivery of goods to the City's specified receiving point, and for shipping or transportation charges for returning to bidder any goods rejected as non-conforming to the specifications.

**21. Delivery and Acceptance**

The City will receive only those goods as authorized by City purchase order. Bidder must obtain City employee signature upon delivery. Bidder warrants that all deliveries relating to this solicitation be of the type and quality specified by the City. The City may refuse or reject any delivery failing to meet specifications and shall not be held to have accepted any delivery until after it has made an inspection of same. The City is the final judge as to acceptability of goods under this solicitation.

**22. Failure to Deliver**

If a bidder is unable to deliver the quantity or quality of specified goods, or is unable to deliver goods within a time period when included in the specifications, the City shall be authorized to purchase from any other available source, consistent with State of Texas procurement statutes.

**23. MSDS**

Bidders must submit Material Safety Data Sheets for any hazardous chemical quoted or supplied under this solicitation.

**24. Taxpayer Identification**

Bidders must provide the City with a current W-9 "Request for Taxpayer Identification and Certification" before goods or services can be procured from the bidder.

**25. Taxes**

The City is exempt from all federal excise taxes and all state and local sales and use taxes. If such taxes are listed on a bidder's invoice, they will not be paid. Additionally, bidders cannot use the City's tax exemption status to purchase goods or services related to this solicitation.

**26. Payment**

Payment will be made after receipt of all invoiced goods. Bidder will be paid within thirty days of date invoice is received or date goods are received, which is later. Additional discount may be taken by the City based on the Summary Response Page. The discount date begins with the date the invoice is received or the date all items covered by the invoice is received, whichever is later. Bidder is entitled to interest, at a rate stipulated by state law, if payment is not made within thirty days.

## 27. Outstanding Liabilities

Bidders shall not have outstanding, unpaid liabilities owed to the City. Liabilities may include, but are not limited to, property taxes, hotel occupancy taxes, license or permit fees, and water bills. Bids will be considered non-responsible and not given further consideration if submitted by a bidder with such outstanding liabilities.

## 28. Offset

The City may, at its option, offset any amounts due and payable under a contract award under this solicitation against any debt lawfully due the City from a vendor, whether or not the amount due arises pursuant to the terms of the contract and whether or not the debt has been reduced to judgment by a court.

## 29. Independent Contractors

It is expressly agreed and understood by both parties that the City is contracting with the successful bidder as an independent contractor. The City shall not be liable for any claims which may be asserted by any third party occurring in connection with services performed by the successful bidder, and the successful bidder has no authority to bind the City.

## 30. New Products

The City will accept only new products, such products having not been used or owned by any entity, company or individual except the manufacturer and the manufacturer's distributors. Used or reconditioned products will not be accepted unless specifically requested in the accompanying solicitation.

## 31. Warranties

Bidder warrants that any and all goods delivered are newly manufactured, free from defects in materials and workmanship, and conform in every respect to the City's specifications. Goods are warranted for one year from date of acceptance by the City, following delivery and inspection. If at any time during the twelve months following acceptance of the goods, said goods fail to perform their intended purpose or are discovered to be defective or nonconforming to the City's specifications, the bidder will replace the goods at no cost to the City, including any delivery or installation costs. This warranty shall be unconditional, except it shall not apply to damage caused by clear abuse or misuse by the City. If a manufacturer of goods or of component parts of goods provides a warranty longer than the period provided for herein, the provisions of this warranty shall not be construed to diminish or conflict with the manufacturer's warranty.

## 32. Governing Law

All bids submitted in response to this solicitation and any resulting contract shall be governed by, and construed in accordance with, the charter and ordinances of the City of Irving, and the laws and court decisions of the State of Texas.

## 33. Controlling Document

In the case of a discrepancy between this solicitation and the formal contract, the formal contract will prevail and control.

## 34. Assignment

Bidder shall not assign, transfer, or pledge a contract awarded under this solicitation, in whole or in part, with the prior written consent of the City's purchasing manager. Assignment of this contract, if approved by the City, shall not relieve the bidder's obligations under the contract. Approval by the City of one assignment shall not constitute approval of any future assignment of the contract.

### 35. Termination

If an awarded bidder fails in any manner to fully perform each and all of the terms, conditions and covenants of a contract awarded by this solicitation, he shall be in default and notice of default shall be given to the bidder by the City's purchasing manager. In the event that the contractor continues in default for a period of seven (7) days after receipt of the above-mentioned notice of default, the City may terminate or cancel the contract. The City may also cancel a contract for convenience and without cause with thirty days notice. In any cancellation of contract, the City will pay the bidder for all goods received and accepted, and for all services provided and accepted up to and including the date of termination.

### 36. Indemnification

Bidder shall defend, indemnify, and hold harmless the City of Irving, its officers, agents, employees, appointees and volunteers against any and all claims, lawsuits, judgments, costs and expenses for personal injury (including death), property damage or other harm for which recovery of damages is sought, suffered by any person or persons, that may arise out of or be occasioned by bidder's breach of any of the terms or provisions of any contract awarded as a result of this solicitation, or by any negligent or strictly liable act or omission of the bidder, its officers, agents, employees, or subcontractors, in the performance of an awarded contract; except that the indemnity provided for in this paragraph shall not apply to any liability resulting from the sole negligence or fault of the City, its officers, agents or employees, and in the event of joint and concurrent negligence or fault of the bidder and City, responsibility and indemnity, if any, shall be apportioned comparatively in accordance with the laws of the State of Texas, without waiving any governmental immunity available to the City under Texas law and without waiving any defenses of the parties under Texas law. The provisions of this paragraph are solely for the benefit of the parties hereto and are not intended to create or grant any rights, contractual or otherwise, to any other person or entity.

### 37. Venue

The obligations of all parties under a contract awarded through this solicitation are performed in Dallas County, Texas, and if legal action is necessary to enforce same, exclusive venue shall be within Dallas County, Texas.

### 38. Funding

State of Texas statutes prohibit the obligation and expenditure of public funds beyond the fiscal year for which a budget has been approved. Orders or other obligations that may arise beyond the end of the current fiscal year shall be subject to approval of budget funds.

### 39. Solicitation Results

The City normally posts solicitation results on-line by the end of the next business day after bids are received. The City's Web site is [www.cityofirving.org](http://www.cityofirving.org). Results are on the Purchasing Solicitation page, in the same place as the original solicitation documents. Posted results are for informational purposes only, not a notice of award.

### 40. Open Records

Bid pricing is not considered confidential and is open to public inspection. Trade secrets and other material considered confidential by the bidder should be clearly marked as such. If a request is made under the Texas Open Records Act to inspect information designated as a trade secret or confidential in a bid, the City will forward the appropriate documents to the Attorney General of Texas who will contact the bidder to request sufficient written reasons as to why the information should be protected from disclosure. Upon review of the bidder's response, the Attorney General will make a determination as to the confidentiality of the requested material(s), or lack thereof, and the City will respond accordingly.

# GENERAL INSTRUCTIONS TO BIDDERS

Attachment B-1 (rev. 12/31/08)

## 1. Securing Specifications

Free specifications may be downloaded from the Purchasing page of the City's Web site, [www.cityofirving.org](http://www.cityofirving.org). The City of Irving does not charge for specifications. If a third-party offers specifications or bid information for a fee, they do not represent the City. The City may charge for plans and drawings for construction solicitations.

## 2. Submission of Bids/Late Bids

Bid pricing must be in US dollars and cents, unless a "percentage off" is requested. Bidders are to provide enough information with their bid to constitute a definite, firm, unqualified and unconditional offer. Bids are to be submitted in a sealed envelope or package and labeled with the bidder's name and the solicitation name & number. All bids must be submitted to the City of Irving Purchasing Division no later than the date and time indicated in the solicitation. All times listed are local times. It is the bidder's responsibility to ensure that bids are delivered/received by the specified time. Late bids will not be accepted and will be returned unopened.

## 3. Legal Name of Bidder

In completing the Summary Response Page, the bidder must list the legal name of the bidder's company. This is the name that will be on all contracts, awards, and purchase orders. The Summary Response Page also requires a statement as to the legal status of the bidder (corporation, partnership, sole proprietorship, etc.). The Summary Response Page should be the first document in the bidder's response.

## 4. Signature

The signature on the Summary Response Page must be in ink and from an individual with the authority to commit the company to the prices bid and terms stated.

## 5. Altered Bids

Any alterations, erasures or strikethroughs made by the bidder prior to submission of the bids must be initialed by the bidder to guarantee authenticity.

## 6. Cooperative Purchase

Bidders are given an opportunity on the Summary Response Page to indicate their willingness to allow other public entities to use the bid response as a basis for a contract with their entity, in lieu of competitive bidding. This provision is in compliance with Local Government Code 271.102.

## 7. Payment Terms, Discount & Type of Payment

Bidder should state payment terms on the Summary Response Page. If the bidder fails to indicate payment terms, the City will use the default of 2%/30 days. The bidder may also express the method(s) in which he or she wishes to receive payment.

## 8. References

When references are requested, the Summary Response Page will indicate how many references and will state what other conditions may apply to the references. Bidder will attach a separate page with the requested references.

9. **Conflict of Interest**  
Bidders should review the instructions on conflict of interest (Attachment C-1). Bidders are to complete and submit the Conflict of Interest form (Attachment C-2), when a conflict of interest exists.
10. **Environmental Stewardship**  
Bidders are encouraged to review the City's commitment to the environment (Attachment E-1). Bidders are to complete and submit the Environmental Stewardship form (Attachment E-2).
11. **Good Faith Effort**  
Bidders are encouraged to review information on the City's Good Faith Effort program (Attachment G-1). Bidders are to complete and submit the Good Faith Effort Affidavit (Attachment G-2). Recommended bidder(s) will be required to complete the additional GFE forms as part of the award process.
12. **Addendums**  
It is the bidder's responsibility to alter his bid response based on information updated in one or more addendums to the solicitation. Addendums will be posted on the Purchasing solicitation page of the City's Web site at least four days before the bid due date. Efforts will be made to ensure that bidders receive notice of addendums, but the ultimate responsibility rests with the bidder.
13. **Exceptions**  
If a bidder takes exception to any part of the specifications or solicitation documents, such exception must be requested in writing, to the Purchasing agent/manager listed in the solicitation, at least six business days before the bid due date or within 24 hours of a pre-bid meeting, whichever is earlier. Approved exceptions will be included in an addendum and posted on the Purchasing Solicitation page of the City's Web site.
14. **Checklist**  
A Bidder's Checklist (Attachment B-3) is included with the solicitation package. The checklist is an aid to the bidder in knowing which documents to submit.
15. **Hot Line**  
Vendors may call 888-223-9524 to anonymously report instances of fraud, waste or abuse. Please provide as many details as possible.

# SPECIAL INSTRUCTIONS TO BIDDERS

Attachment B-2 (rev. 12/31/08)

## 1. Bidding Process/Contact Information

The City of Irving is aware of the time and effort bidders spend in preparing and submitting bids. We will work with you to make the process as easy as possible. If you have questions or concerns about the bidding process, please contact:

**Darlene Rush, Senior Purchasing Agent**

[drush@cityofirving.org](mailto:drush@cityofirving.org)

**972.721.3752**

## 2. Method of Award

Award will be made in its entirety to the lowest responsive, responsible bidder. The City reserves the right to award by whichever method is most favorable to the City, but will award to the lowest, responsive, responsible bidder no matter which method is used. Awards totaling \$50,000 or more will be made by the Irving City Council.

## 3. Public Bid Opening

A public bid opening will be held at 3:00 p.m. on November 13, 2009 in the Purchasing Conference Room, 845 W. Irving Blvd., Irving, TX 75060.

## 4. Specifications

The City reserves the right to accept minor alterations that do not affect the integrity, design, and functionality of the poles/assemblies. Overall functionality and overall appearance must be acceptable to the City.

## 5. Exhibits to be Submitted with Bid

Bidders should submit, with his bid, sufficient information to permit the evaluation of the product he proposes to furnish. The following information, as a minimum, must be supplied with the bid or the bid will be non-responsive and not considered for award.

- ◆ One copy of the shop drawings and/or catalog cuts of each proposed assembly.
- ◆ A detailed list and drawings of suggested design modifications and exceptions on the City of Irving's pole assembly designs.
- ◆ Type steel / aluminum and minimum yield strength after fabrication of all components.
- ◆ All warranties and/or guarantees with respect to materials, workmanship and performance of his products.
- ◆ Sample of color
- ◆ Statement of delivery time
- ◆ Quality Assurance Plan

## CHECKLIST FOR BIDDERS

Attachment B-3 (rev. 12/31/08)

### Documents to be submitted in response to this Invitation to Bid (ITB)

\_\_\_\_\_ **BID PRICING PAGE:** (All Lines/Blanks Completed, including delivery time)

\_\_\_\_\_ **BID RESPONSE:** (Completed Summary Response Page)

\_\_\_\_\_ **DUE DATE:** (Bid must be received & stamped in Purchasing no later than  
3:00 pm on November 13, 2009)

\_\_\_\_\_ **EXHIBITS LISTED IN SPECIAL INSTRUCTIONS:** (Item 5, page 16)

**Bids failing to comply with the above will be deemed non-responsive.**

**The following items should be turned in with the bid. Documents must be received before award recommendation.**

\_\_\_\_\_ **GOOD FAITH EFFORT AFFIDAVIT** (Attachment F-2)

\_\_\_\_\_ **ENVIRONMENTAL STEWARDSHIP** (Attachment E-2)

\_\_\_\_\_ **CONFLICT OF INTEREST STATEMENT** (If applicable) (Attachment C-2)

\_\_\_\_\_ **REFERENCES** (As requested on the Summary Response Page)

\_\_\_\_\_ **STANDARD CONTRACT FOR SERVICES** (Attachment H-2)

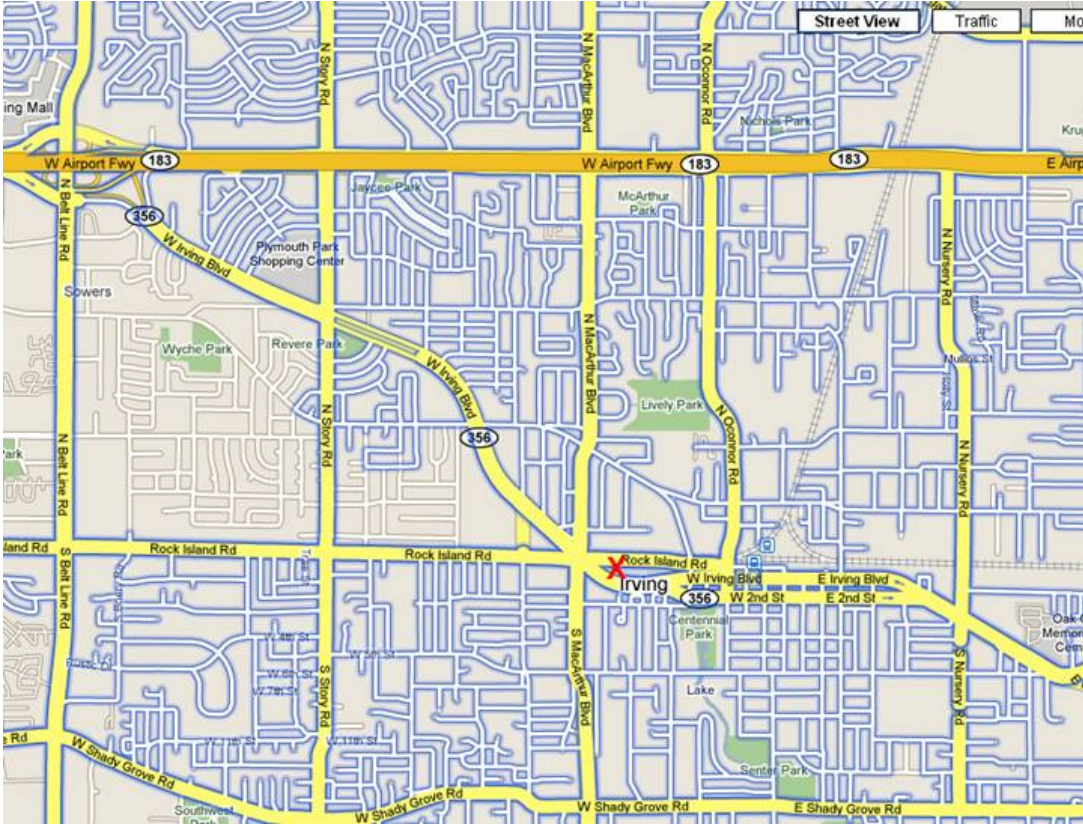

1.

## Location of City of Irving Purchasing Division Attachment B-5 (rev. 12/31/08)



**INSTRUCTIONS for  
CONFLICT OF INTEREST QUESTIONNAIRE**  
Attachment C-1 (rev. 12/31/08)

1. If you have a conflict of interest in doing business with the City of Irving, use Attachment C-2, Conflict of Interest questionnaire. Conflicts of interest are addressed in Texas Local Government Code, Chapter 176.

2. You may consult your attorney on questions arising from the reading of Texas Local Government Code, Chapter 176, and you may contact the Texas Ethics Commission at 512-463-5800 or 800-325-8506.

3. If you complete Attachment C-2, Conflict of Interest questionnaire:

- Put the name of bidder and name of company in block #1.
- If any person employed by bidder or bidder's company has any known business conflicts, other than previous contracts awarded through a competitive bidding process, or has an existing relationship with any employee of the City of Irving, list that information in blocks #3, #4 and/or #5 as appropriate.
- Sign in block #6.

4. To view a listing of conflict of interest forms filed with the City of Irving, please click

<http://cityofirving.org/city-secretary/conflict-of-interest/conflict-of-interest-forms.html>

5. Listings of City elected officials and local government officers may be found on the City's Web site: [www.cityofirving.org](http://www.cityofirving.org).

6. A person failing to file a Conflict of Interest questionnaire, when required by Local Government Code, Chapter 176, commits a Class C misdemeanor.

**Attachment C-2**

<b>CONFLICT OF INTEREST QUESTIONNAIRE</b> <b>For vendor or other person doing business with local governmental entity</b>		<b>FORM CIQ</b>
<p>This questionnaire is being filed in accordance with chapter 176 of the Local Government Code by a person doing business with the governmental entity.</p> <p>By law this questionnaire must be filed with the records administrator of the local government not later than the 7th business day after the date the person becomes aware of facts that require the statement to be filed. See Section 176.006, Local Government Code.</p> <p>A person commits an offense if the person violates Section 176.006, Local Government Code. An offense under this section is a Class C misdemeanor.</p>		<b>OFFICE USE ONLY</b>
Date Received		
<b>1</b>	<b>Name of person doing business with local governmental entity.</b>	
<b>2</b>	<input type="checkbox"/> <b>Check this box if you are filing an update to a previously filed questionnaire.</b>  (The law requires that you file an updated completed questionnaire with the appropriate filing authority not later than September 1 of the year for which an activity described in Section 176.006(a), Local Government Code, is pending and not later than the 7th business day after the date the originally filed questionnaire becomes incomplete or inaccurate.)	
<b>3</b>	<b>Name each employee or contractor of the local governmental entity who makes recommendations to a local government officer of the governmental entity with respect to expenditures of money AND describe the affiliation or business relationship.</b>	
<b>4</b>	<b>Name each local government officer who appoints or employs local government officers of the governmental entity for which this questionnaire is filed AND describe the affiliation or business relationship.</b>	

Adopted 11/02/2005

**CONFLICT OF INTEREST QUESTIONNAIRE**

**For vendor or other person doing business with local governmental entity**

**5 Name of local government officer with whom filer has affiliation or business relationship. (Complete this section only if the answer to A, B, or C is YES.**

This section, item 5 including subparts A, B, C & D, must be completed for each officer with whom the filer has affiliation or other relationship. Attach additional pages to this Form CIQ as necessary.

A. Is the local government officer named in this section receiving or likely to receive taxable income from the filer of the questionnaire?  Yes  No

B. Is the filer of the questionnaire receiving or likely to receive taxable income from or at the direction of the local government officer named in this section AND the taxable income is not from the local governmental entity?  Yes  No

C. Is the filer of this questionnaire affiliated with a corporation or other business entity that the local government officer serves as an officer or director, or holds an ownership of 10 percent or more?  Yes  No

D. Describe each affiliation or business relationship.

**6**

\_\_\_\_\_  
Signature of person doing business with the governmental entity

\_\_\_\_\_  
Date

Adopted 11/02/2005





**NO INSURANCE  
REQUIREMENTS  
FOR THIS ITB**

*Attachment D-9 (rev. 12/31/08)*

## ENVIRONMENTAL COMMITMENT & COMPLIANCE

Attachment E-1 (rev. 12/31/08)

Because the City of Irving is committed to protecting the environment and becoming a successful environmentally sustainable community, it is essential that environmental considerations be a part of all City activities and operations. This commitment is demonstrated through;

-  Compliance
-  Environmental Sustainability
-  Continued Improvement
-  Pollution Prevention

As a contactor/vendor/consultant for the City of Irving your environmental performance is critical in meeting the City's commitment to protect the environment and comply with all environmental laws and regulations.

There are many laws and regulations relating to the protection of the environment. In these laws, all persons share responsibility for the environment. It is your responsibility as a contractor to know which laws, regulations, approvals or permits relate to the work you are doing for the City of Irving. It is also your responsibility as a contractor to comply with all applicable laws and ensure all requirements imposed by these laws are met

The City of Irving has a commitment to being good stewards of the environment. We expect your commitment, as a City contractor/vendor/consultant, to the same goal.

# ENVIRONMENTAL STEWARDSHIP

Attachment E-2 (rev. 12/31/08)

Recognizing the importance of exercising positive environmental stewardship, The City of Irving is pro-active in encouraging environmentally-sound practices in our operations and among our residents, businesses, and suppliers. Please review the specifications or scope of work for this solicitation for any environmental requirements.

Check any of the following which apply to your business operation, and list details:

\_\_\_\_\_ **Recycling** \_\_\_\_\_  
\_\_\_\_\_

\_\_\_\_\_ **Energy Efficiency Practices** \_\_\_\_\_  
\_\_\_\_\_

\_\_\_\_\_ **Environmentally Preferred** \_\_\_\_\_  
\_\_\_\_\_

\_\_\_\_\_ **Water/Energy Conservation** \_\_\_\_\_

\_\_\_\_\_ **Air Quality/Emissions** \_\_\_\_\_

\_\_\_\_\_ **Disposal Practices** \_\_\_\_\_

\_\_\_\_\_ **Other Environmentally Friendly Practices** \_\_\_\_\_  
\_\_\_\_\_  
\_\_\_\_\_

**Bidder** \_\_\_\_\_

ITB 046D-10F

**Date** \_\_\_\_\_

## GOOD FAITH EFFORT PROGRAM OVERVIEW

### Attachment F-1 (rev. 12/31/08)

All bid documents and proposal packages must include the signed GFE affidavit affirming the bidder/proposer's intent to comply with the City's Good Faith Effort program. Unless otherwise indicated in the ITB or RFP documents, no other GFE documentation will be required at time of bid or submission. Upon notification of intent to recommend award of contract, the apparent low bidder/most advantageous proposer has up to five (5) business days to submit the appropriate GFE forms to the City's M/WBE Program Administrator. Required GFE forms must be submitted prior to award by City Council.

#### The GFE forms are:

- **GFE-1** Good Faith Effort Affidavit (included as Attachment F-2)
- **GFE-2** Schedule of M/WBE Participation
- **GFE-3** Good Faith Effort Log
- **GFE-4** Intent to Perform as a Sub-Contractor
- **GFE-5** Payment Report

***NOTE: Forms GFE-2 thru GFE-5 are available on the City's Web site in the Purchasing section, under "Forms."***

1. All bidders or proposers must submit form **GFE-1**, Good Faith Effort Affidavit.
2. Prime contractors who are tentatively recommended for award and who will meet or exceed the GFE goal must submit the following additional forms:
  - GFE-2** Schedule of M/WBE Participation
  - GFE-4** Intent to Perform as Sub-Contractor (one for each sub-contractor)
3. Prime contractors who are tentatively recommended for award and who will NOT meet or exceed the GFE goal must submit the following form:
  - GFE-3** Good Faith Effort LogIn addition, if the contractor has partial participation toward the goal, the following forms are also submitted:
  - GFE-2** Schedule of M/WBE Participation
  - GFE-4** Intent to Perform as Sub-Contractor (one for each sub-contractor)
4. The awarded contractor will submit the following form monthly to verify that the sub-contracting work is being done as agreed upon:
  - GFE-5** Payment Report

**For any GFE communication: Call 972-721-3753 or 972-721-2631**

## GOOD FAITH EFFORT AFFIDAVIT

Attachment F-2 (rev. 12/31/08)

On January 11, 2007, the Irving City Council adopted a policy to equitably and conscientiously include Minority- and Women-owned Business Enterprises (M/WBE's) in the City procurement process for all basic goods, services, professional services, and construction solicitations. The City and its contractors shall not discriminate on the basis of race, color, religion, national origin, or sex in the award and performance of contracts. In consideration of this policy, the City of Irving has implemented the Good Faith Effort (GFE) Program.

### **M/WBE Participation Goals**

The GFE Plan establishes subcontracting goals for all prospective bidders, proposers, and submitters to ensure a reasonable degree of M/WBE participation in City contracts. It is the goal of the City of Irving that a certain percentage of work under each contract be executed by one or more M/WBEs.

The following M/WBE participation goals have been established without consideration for a specific ethnicity or gender:

<b><u>Construction</u></b>	<b><u>Architectural &amp; Engineering</u></b>	<b><u>Professional Services</u></b>	<b><u>Other Services</u></b>	<b><u>Goods</u></b>
30.00%	28.00%	33.00%	20.00%	10.00%

The apparent low bidder/most advantageous proposer shall agree to meet the established goals or must demonstrate and document a "good faith effort" to include M/WBEs in subcontracting opportunities. The apparent low bidder/most advantageous proposer who fails to adequately document good faith efforts to subcontract or purchase significant material supplies from M/WBEs may be denied award of the contract by the City based on the contractor's failure to be a "responsive" proposer or bidder.

**By signing below, I agree to provide the City of Irving with a completed copy of all forms required by Good Faith Effort Program. I understand that if I fail to provide all of the required documents within five (5) business days after notification, my bid or proposal may be deemed "non-responsive" and I may be denied award of the contract.**

ITB 046D-10F

\_\_\_\_\_  
 Typed or Printed Name of Certifying Official of Company

\_\_\_\_\_  
 Date

\_\_\_\_\_  
 Signature of Certifying Official of Company

\_\_\_\_\_  
 Title

Form GFE-1

**NO BONDING  
REQUIREMENTS  
FOR THIS ITB**

**Attachment G-9** (rev. 12/31/08)

**STANDARD CONTRACT AND ACKNOWLEDGMENT**  
**Attachment H-2**

STATE OF TEXAS       §  
COUNTY OF DALLAS §       KNOW ALL PERSONS BY THESE PRESENTS:  
CITY OF IRVING       §

I.

Conditioned upon Vendor being awarded by the Irving City Council, or award being made administratively, the bid items set out in ITB# 046D-10F, and upon order of the City of Irving, Texas, a municipal corporation located in Dallas County, Texas and incorporated as a home rule city under the Constitution of the State of Texas ("City"), Vendor does hereby agree to sell, lease, furnish and/or deliver to City in accordance with the terms of Vendor's submitted Bid Page and the Specifications in above referenced ITB, the items listed as awarded to bidder in the Irving City Council resolution awarding such bid to Vendor, or listed in the Administrative Award. Execution of said Resolution or Administrative Award shall evidence City's acceptance of this contract.

II.

City agrees to pay Vendor for each order at the unit price listed upon the Bid Page and Specifications with payment being subject to any discount terms stated upon the Bid Page, the Summary Response Page, and Specifications, and subject to any payment terms contained elsewhere within this contract and its attachments. Any purchase of items so that the cumulative total of payments under this contract exceeds the amount authorized in the City Council Resolution awarding bid to Vendor will require additional authorization.

III.

It is understood that the following documents, to wit: the Notice to Bidders, the Standard Terms and Conditions, the General Instructions to Bidders, the Special Instructions to Bidders, the Specifications, the Bid Page, and the Summary Response Page are hereby made a part and parcel of this contract and incorporated herein for all purposes.

IV.

The date of any payment, whether net or gross, shall be determined by calculating the number of days after receipt of invoices from Vendor, or after reasonable verification as to quantities and quality herein provided, whichever is later.

V.

Venue of any court action brought directly or indirectly by reason of this contract shall be in Dallas County, Texas. This contract is made and is to be performed in Dallas County, Texas.

VI.

If Vendor fails in any manner to fully perform each and all of the terms, conditions and covenants of this contract, he shall be in default and notice of default shall be given to Vendor by the Purchasing Agent of the City. In the event that Vendor continues in default for a period of seven (7) days after receipt of the above-mentioned notice of default, City may terminate or cancel this contract or at its option may purchase similar units on the open market and recover from Vendor any difference in price thereof.

SIGNED this the \_\_\_\_ day of \_\_\_\_\_, A.D. 2\_\_\_\_\_.

Signature \_\_\_\_\_

Name \_\_\_\_\_

Title \_\_\_\_\_

Company Name \_\_\_\_\_

# STANDARD CONTRACT AND ACKNOWLEDGMENT

---

---

## CORPORATE ACKNOWLEDGMENT

THE STATE OF \_\_\_\_\_ §  
COUNTY OF \_\_\_\_\_ §

BEFORE ME, the undersigned authority, a Notary Public in and for said County and State, on this day personally appeared:

\_\_\_\_\_  
(Print Name) (Print Title)

of the corporation known as \_\_\_\_\_, known to me to be the person and officer whose name is subscribed to the foregoing instrument and acknowledged to me that the same was the act of said corporation, that he or she was duly authorized to perform the same by appropriate resolution of the board of directors of such corporation and that she or he executed the same as the act of such corporation for the purposes and consideration therein expressed, and in the capacity therein stated.

GIVEN UNDER MY HAND AND SEAL OF OFFICE this the \_\_\_\_ day of \_\_\_\_\_, A.D., 2\_\_\_\_\_.

\_\_\_\_\_  
Notary  
Public In and For  
County, \_\_\_\_\_

My Commission expires: \_\_\_\_\_

---

---

## PARTNERSHIP ACKNOWLEDGMENT

THE STATE OF \_\_\_\_\_ §  
COUNTY OF \_\_\_\_\_ §

BEFORE ME, the undersigned authority, a Notary Public in and for said County and State, on this day appeared:

\_\_\_\_\_  
(Print Name) (Print Title)

of \_\_\_\_\_ a partnership, known to me to be the person and partner whose name is subscribed to the foregoing instrument and acknowledged to me that the same was the act of the said partnership, and that she or he was duly authorized as a partner of such partnership to perform same for the purpose and consideration therein expressed, and in the capacity therein stated. GIVEN UNDER MY HAND AND SEAL OF OFFICE this the \_\_\_\_ day of \_\_\_\_\_, A.D., 2\_\_\_\_\_.

\_\_\_\_\_  
Notary Public In and For  
County, \_\_\_\_\_

My Commission expires: \_\_\_\_\_

---

---

## SINGLE ACKNOWLEDGMENT

THE STATE OF \_\_\_\_\_ §  
COUNTY OF \_\_\_\_\_ §

BEFORE ME, the undersigned authority, a Notary Public in and for said County and State, on this day personally appeared \_\_\_\_\_ known to me to be the person whose name is subscribed to the foregoing instrument, and acknowledged to me that he/she executed the same for the purposes and consideration therein expressed.

GIVEN UNDER MY HAND AND SEAL OF OFFICE this the \_\_\_\_ day of \_\_\_\_\_, A.D., 2\_\_\_\_\_

\_\_\_\_\_  
Notary Public In and For  
County, \_\_\_\_\_

My Commission expires: \_\_\_\_\_

**Attachment H-9**

# Attachment I

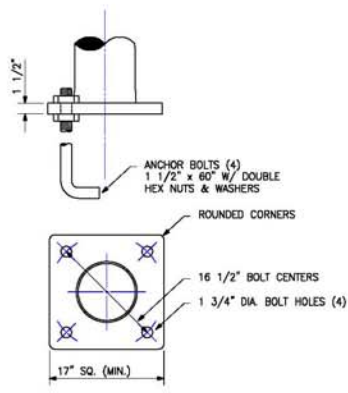

**BASE PLATE DETAIL**  
NTS

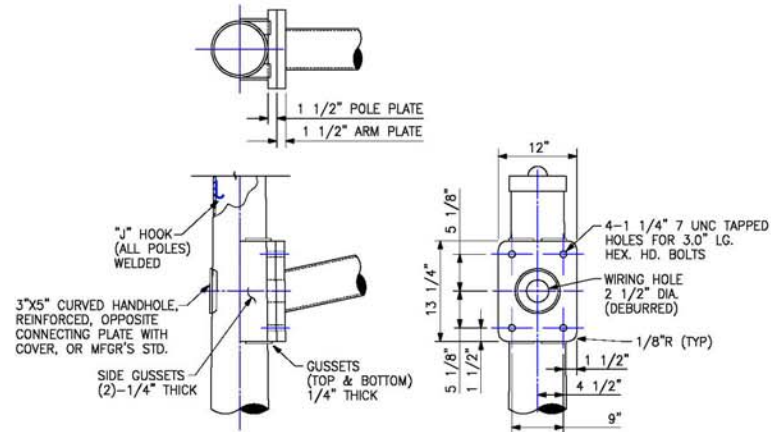

**ATTACHMENT DETAIL**  
Typical All Arm & Pole Plates  
charted this sheet  
NTS

**NOTES:**

1. ALL WELDED JOINTS SHALL DEVELOP THE FULL STRENGTH OF THE ADJACENT MEMBERS.
2. POLE AND TRAFFIC SIGNAL ARM SHAFT - HOT ROLLED COMMERCIAL QUALITY CARBON STEEL WITH 55,000 PSI MINIMUM YIELD STRENGTH. ASTM A595 GRADE A. LINEAR TAPER - 0.14"/FT.
3. BASE PLATE AND SIMPLEX PLATES - 36,000 PSI MINIMUM YIELD STRENGTH. ASTM A36.
4. ANCHOR BOLTS - 55,000 PSI MINIMUM YIELD STRENGTH.
5. SIMPLEX CONNECTING BOLTS - HIGH STRENGTH, A325 GALVANIZED TO ASTM DESIGNATION : A153.
6. POLE AND ARMS TO BE HOT DIP GALVANIZED TO ASTM DESIGNATION : A123
7. ACCESSORIES TO BE HOT DIP GALVANIZED TO ASTM DESIGNATION : A153
8. ALL THREADED FASTENERS TO BE GALVANIZED UNLESS NOTED OTHERWISE.
9. ALL SIGNAL POLE ARM ASSEMBLIES AND EXTERNAL HARDWARE TO BE DARK BRONZE POWDER COATED.

TRAFFIC SIGNAL ARM " L "	DISTANCE " A " (FT.)	RATING	
		EQUIVALENT LOADING (END OF ARM)	WEIGHT (LB) AREA (FT <sup>2</sup> )
.2391"x 10"x 3.84"x 44'-0"	13.5'	167.0	36.0'

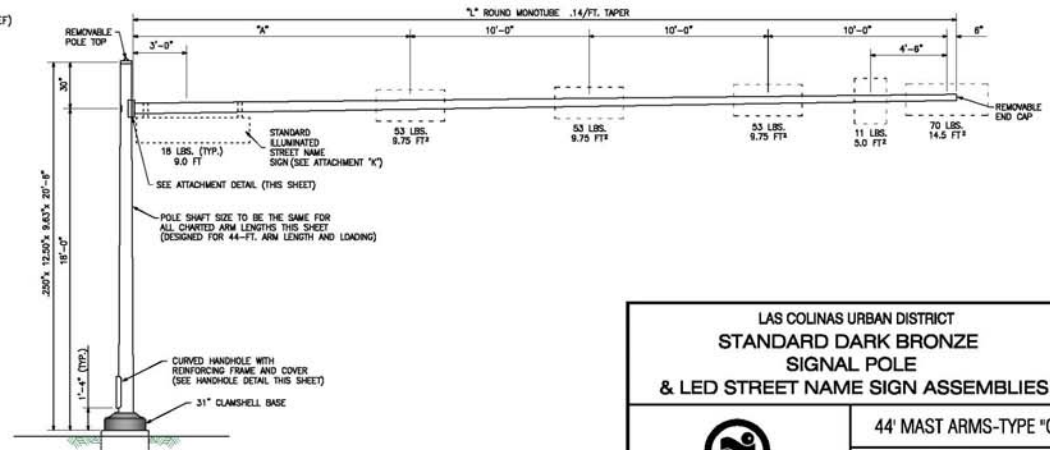
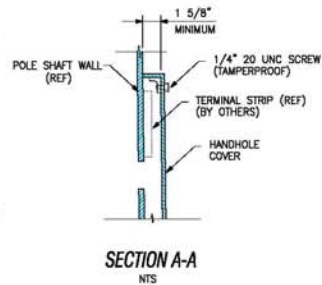
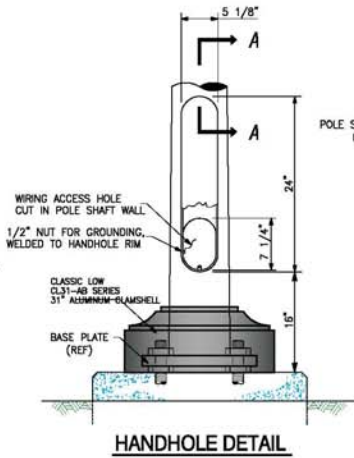
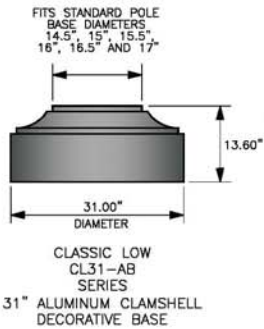

LAS COLINAS URBAN DISTRICT STANDARD DARK BRONZE SIGNAL POLE & LED STREET NAME SIGN ASSEMBLIES	
<p><b>IRVING</b> Transportation Department</p>	44' MAST ARMS-TYPE "C" DESIGNED BY: CITY OF IRVING DRAWN BY: M. JONES CHECKED BY: B. YOUNGER GURLEY SCALE AS SHOWN DATE: 6/2009
	SHT. of