

ORDINANCE NO. _____

AN ORDINANCE AMENDING THE LAND DEVELOPMENT CODE OF THE CITY OF IRVING, TEXAS, BY ADDING SECTIONS 8B-27 THROUGH 8B-29, ADOPTING THE 2021 EDITION OF THE INTERNATIONAL SWIMMING POOL AND SPA CODE AS THE SWIMMING POOL AND SPA CODE FOR THE CITY OF IRVING, TEXAS; PROVIDING LOCAL AMENDMENTS, ADDITIONS, AND DELETIONS THERETO; ADOPTING PENALTY PROVISIONS; AND PROVIDING FOR SEVERABILITY, SAVINGS, AND AN EFFECTIVE DATE.

WHEREAS, the North Central Texas Council of Governments encourages local jurisdictions to adopt the 2021 International Codes; and

WHEREAS, the Construction Board of Appeals, among its other duties, has been created to obtain public comment on the periodic update of the code; and

WHEREAS, the Construction Board of Appeals has conducted a public meeting to receive public comments from persons affected by the proposed amendments to the code, and recommends adoption of the 2021 International Swimming Pool and Spa Code as the Swimming Pool and Spa Code for the City with the following local amendments.

NOW, THEREFORE, BE IT ORDAINED BY THE CITY COUNCIL OF THE CITY OF IRVING, TEXAS:

SECTION 1. That Chapter 8B entitled “Building Codes” of The Land Development Code of the City of Irving, Texas, is hereby amended by adding Sections 8B-27, 8B-28, and 8B-29 to read as follows:

Sec. 8B-27. International Swimming Pool and Spa Code.

The 2021 edition of the International Swimming Pool and Spa Code is adopted as the swimming pool and spa code of the City of Irving, Texas, as amended herein.

Sec. 8B-28. Local Amendments, additions, and deletions to the 2021 edition of the International Swimming Pool and Spa Code.

Amendments included in this section are intended to be specific code provisions. If there is a conflict between a provision in the published 2021 International Swimming Pool and Spa Code and this section, the specific provisions of this section shall control. Amendments, modifications, and deletions to the 2021 International Swimming Pool and Spa Code are adopted as follows:

- a) Chapter 1 (Scope and Administration), Section 101.1 is amended to read as follows:
101.1 Title. These regulations shall be known as the Swimming Pool and Spa Code of the City of Irving, hereinafter referred to as “this code” or “ISPSC.”
- b) Chapter 1 (Scope and Administration), Section 102.9 is amended to read as follows:

Section 102.9 Other laws. The provisions of this code shall not be deemed to nullify any provisions of local, state or federal law, to include but not limited to:

1. Texas Department of State Health Services (TDSHS); Standards for Public Pools and Spas; §285.181 through §285.208, (TDSHS rules do not apply to pools serving one- and two-family dwellings or townhouses).
2. Texas Department of Licensing and Regulation (TDLR); 2012 Texas Accessibility Standards (TAS), TAS provide the scoping and technical requirements for accessibility for Swimming Pool, wading pools and spas and shall comply with 2012 TAS, Section 242. (TAS rules do not apply to pools serving one- and two-family dwellings or townhouses).

Exception: Elements regulated under Texas Department of Licensing and Regulation (TDLR) and built in accordance with TDLR approved plans, including any variances or waivers granted by the TDLR, shall be deemed to be in compliance with the requirements of this Chapter.

- c) Chapter 1 (Scope and Administration), Section 103.1 is amended to read as follows:
103.1 Creation of agency. The Department of Inspections is hereby created and the official in charge thereof shall be known as the code official. The function of the agency shall be the implementation, administration, and enforcement of the provisions of this code.
- d) Chapter 1 (Scope and Administration), Section 112 (Board of Appeals) is deleted in its entirety.
- e) Chapter 1 (Scope and Administration), Section 113.4 is amended to read as follows:
113.4 Violation penalties. Any person who shall violate a provision of this code or shall fail to comply with any of the requirements thereof or who shall erect, install, alter or repair a pool or spa in violation of the approved construction documents or directive of the code official, or of a permit or certificate issued under the provisions of this code may be punishable for each day of the violation set forth by the authority having jurisdiction.
- f) Chapter 3 (General Compliance), Section 305.1 is amended to read as follows:
305.1 General. The provisions of this section shall apply to the design of barriers for restricting entry into areas having pools and spas. In only one-and two-family dwellings and townhouses, where spas or hot tubs are equipped with a lockable safety cover complying with ASTM F1346 and swimming pools are equipped with a powered safety cover that complies with ASTM F1346, the areas where those spas, hot tubs or pools are located shall not be required to comply with Sections 305.2 through 305.7.
- g) Chapter 3 (General Compliance), Section 305.2.7 is amended to add Section 305.2.7.1 to read as follows:
305.2.7.1 Chain link fencing prohibited. Chain link fencing is not permitted as a barrier in public pools built after January 1, 1994.
- h) Chapter 3 (General Compliance), Section 305.4 is amended to read as follows:
305.4 Structure wall as a barrier. Where a wall of a dwelling or structure of a one- and two-family dwelling or townhouse or its accessory structure serves as part

of a barrier and where doors or windows provide direct access to the pool or spa through that wall, one of the following shall be required:

1. Operable windows having a sill height of less than 48 inches (1219 mm) above the indoor finished floor, doors and gates shall have an alarm that produces an audible warning when the window, door or their screens are opened. The alarm shall be listed and labeled as a water hazard entrance alarm in accordance with UL 2017.
2. In dwellings not required to be Accessible units, Type A units or Type B units, the operable parts of the alarm deactivation switches shall be located at not less than 54 inches (1372 mm) above the finished floor.
3. In dwellings that are required to be Accessible units, Type A units or Type B units, the operable parts of the alarm deactivation switches shall be located not greater than 54 inches (1372 mm) and not less than 48 inches (1219 mm) above the finished floor.
4. In structures other than dwellings, the operable parts of the alarm deactivation switches shall be located not greater than 54 inches (1372 mm) and not less than 48 inches (1220 mm) above the finished floor.
5. A safety cover that is listed and labeled in accordance with ASTM F1346 is installed for the pools and spas.
6. An approved means of protection, such as self-closing doors with self-latching devices, is provided. Such means of protection shall provide a degree of protection that is not less than the protection afforded by Item 1 or 2.

i) Chapter 3 (General Compliance), Section 305.6 is amended to read as follows:

305.6 Natural barriers used in a one- and two-family dwelling or townhouse.

In the case where the pool or spa area abuts the edge of a lake or other natural body of water, public access is not permitted or allowed along the shoreline, and required barriers extend to and beyond the water's edge a minimum of eighteen (18) inches, a barrier is not required between the natural body of water shoreline and the pool or spa.

j) Chapter 3 (General Compliance), Section 307.1.4 is amended to add an exception to read as follows:

Exception: Components of projects regulated by and registered with Architectural Barriers Division of Texas Department of Licensing and Regulation shall be deemed to be in compliance with the requirements of this chapter.

k) Chapter 3 (General Compliance), Section 307.2.2 is amended to add Section 307.2.2.2 to read as follows:

Section 307.2.2.2. Adjacency to Structural Foundation. Depth of the swimming pool and spa shall maintain a ratio of 1:1 from the nearest building foundation or footing of a retaining wall.

Exception: A sealed engineered design drawing of the proposed new structure shall be submitted for approval.

l) Chapter 3 (General Compliance), Section 310.1 is amended to read as follows:

310.1 General. Suction entrapment avoidance for pools and spas shall be provided in accordance with APSP 7 (ANSI/PHTA/ICC 7) or for public swimming pools in accordance with State of Texas Rules for Public Swimming Pools and Spas, Title 25 TAC Chapter 265 Subchapter L, Rule §265.190.

Exceptions.

1. Portable spas and portable exercise spas listed and labeled in accordance with UL 1563 or CSA C22.2 No. 218.1.
2. Suction entrapment avoidance for wading pools shall be provided in accordance with Section 405.

m) Chapter 4 (Public Swimming Pools), Section 402.12 is amended to read as follows:

402.12 Water envelopes. The minimum diving water envelopes shall be in accordance with Table 402.12 Texas department of State Health services, Administrative Code Title 25, Chapter 265, Section 186 (e) and Figure: 25 TAC 256.186 (e) (6). (Delete Table 402.12 and Figure 402.12)

ADD: Figure: 25 TAC §265.186 (e) (6)

Maximum Diving Board Height Over Water	¾ Meter	1 Meter	3 Meters
Max. Diving Board Length	12 ft.	16 ft.	16 ft.
Minimum Diving Board Overhang	2 ft. 6 in.	5 ft.	5 ft.
D1 Minimum	8 ft. 6 in.	11 ft. 2 in.	12 ft. 2 in.
D2 Minimum	9 ft.	10 ft. 10 in.	11 ft. 10 in.
D3 Minimum	4 ft.	6 ft.	6 ft.
L1 Minimum	4 ft.	5 ft.	5 ft.
L2 Minimum	12 ft.	16 ft. 5 in.	19 ft. 9 in.
L3 Minimum	14 ft. 10 in.	13 ft. 2 in.	13 ft. 11 in.
L4 Minimum	30 ft. 10 in.	34 ft. 7 in.	38 ft. 8 in.
L5 Minimum	8 ft.	10 ft.	13 ft.
H Minimum	16 ft.	16 ft.	16 ft.
From Plummet to Pool Wall at Side	9 ft.	10 ft.	11 ft. 6 in.
From Plummet to Adjacent Plummet	10 ft.	10 ft.	10 ft.

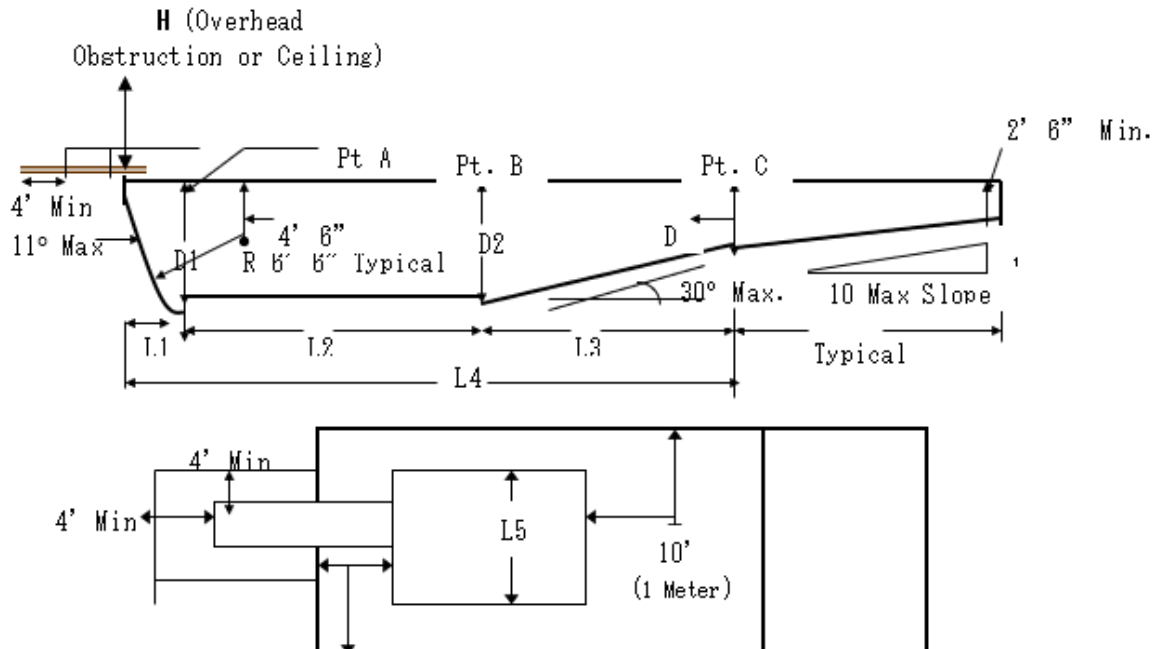

- n) Chapter 4 (Public Swimming Pools), Section 411.2.1 is amended to read as follows:
411.2.1 Tread dimensions and area. Treads shall have a minimum unobstructed horizontal depth (i.e., horizontal run) of 12 inches and a minimum width of 20 inches.
- o) Chapter 4 (Public Swimming Pools), Section 411.2.2 is amended to read as follows:
411.2.2 Risers. Risers for steps shall have a maximum uniform height of 10 inches, with the bottom riser height allowed to taper to zero
- p) Chapter 4 (Public Swimming Pools), Section 411.5.1.4 is amended to read as follows:
411.5.1.4 The leading edge shall be visibly set apart and provided with a horizontal solid or broken stripe at least 1 inch wide on the top surface along the front leading edge of each step. This stripe shall be plainly visible to persons on the pool deck. The stripe shall be a contrasting color to the background on which it is applied, and the color shall be permanent in nature and shall be a slip-resistant surface.
- q) Chapter 4 (Public Swimming Pools), Section 411.5.2.5 is amended to read as follows:
411.5.2.5 The leading edge shall be visually set apart and provided with a horizontal solid or broken stripe at least 1 inch wide on the top surface along the front leading edge of each step. This stripe shall be plainly visible to persons on the pool deck. The stripe shall be a contrasting color to the background on which it is applied, and the color shall be permanent in nature and shall be a slip-resistant surface.
- r) Chapter 6 (Aquatic Recreation Facilities), Section 610.5.1 is amended to read as follows:
610.5.1 Uniform height of 10 inches. Except for the bottom riser, risers at the centerline shall have a maximum uniform height of 10 inches (254 mm). The bottom riser height shall be permitted to vary from the other risers.

- s) Chapter 8 (Permanent Inground Residential Swimming), Section 804.1 is amended to read as follows:

Section 804.1 General. The minimum diving water envelopes shall be in accordance with Table 804.1 and Figure 804.1, or the manufacturer's specifications, whichever is greater. Negative construction tolerances shall not be applied to the dimensions of the minimum diving water envelopes given in Table 804.1.

Sec. 8B-29. Penalty.

- a) A person commits an offense if the person violates a provision of the 2021 International Swimming Pool and Spa Code, as adopted and amended by the City of Irving, allows another person to violate a provision of the 2021 International Swimming Pool and Spa Code, as adopted and amended by the City of Irving, or fails to perform an act required of the person by the 2021 International Swimming Pool and Spa Code, as adopted and amended by the City of Irving. A person commits a separate offense each day or portion of a day during which the violation is committed, allowed, or continued.
- b) An offense described in Section 8B-29(a) is a class "C" misdemeanor and shall be punishable by a fine not to exceed \$500.00. However, a fine for the violation of a provision of this chapter that governs fire safety, zoning, or public health and sanitation, including dumping or refuse, may not exceed \$2,000.00.
- c) The penalties provided for in this section are in addition to any other enforcement remedies that the city may have under other city ordinances or state law.

SECTION 2. That terms and provisions of this ordinance shall be deemed to be severable and that if the validity of any section, subsection, sentence, clause, or phrase of this ordinance should be declared to be invalid, the same shall not affect the validity of any other section, subsection, sentence, clause, or phrase of this ordinance.

SECTION 3. That it is the intent of the Irving City Council that pending prosecutions, brought under the previous code, which this ordinance replaces, should continue under the terms and penalties of said code and be saved from dismissal as if said prior ordinances had not been repealed.

SECTION 5. That this ordinance shall become effective on February 13, 2023.

PASSED AND APPROVED BY THE CITY COUNCIL OF THE CITY OF IRVING, TEXAS,
on _____.